



Capacities from 50 to 520 tonnes

Stroke lengths from 45 to 51mm

Working pressure 700 Bar

B

The HFL low height single acting failsafe lock ring cylinder range combines all the versatility and efficiency of hydraulic power with the safety of mechanical load support, offering a sustainable lifting force in very confined work areas. Ideally suited for applications requiring load holding for extended periods, such as bridge support work. The HFL range features a single acting load return piston, threaded throughout its stroke length to suit the threaded mechanical load holding lock ring. All models are suitable for vertical lifting only and are supplied with tilting saddles as standard.

- >> Single acting load return design
- >> Nitrocarburised cylinder and piston rod for corrosion protection
- >> Low friction bearing surfaces
- >> Anti-extrusion seals
- >> Tilting saddle fitted as standard
- >> Overstroke restrictor port
- >> See pages 27 - 48 for pumps suitable for use with all Hi-Force cylinders

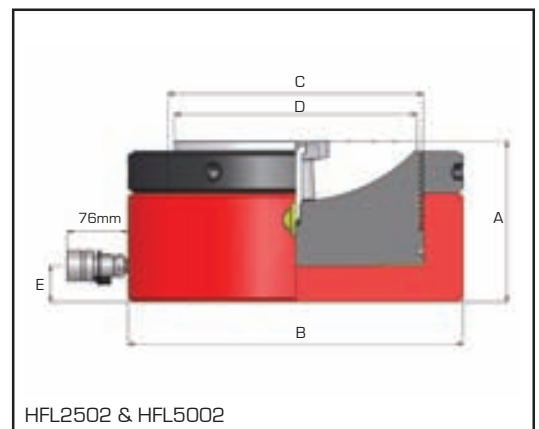
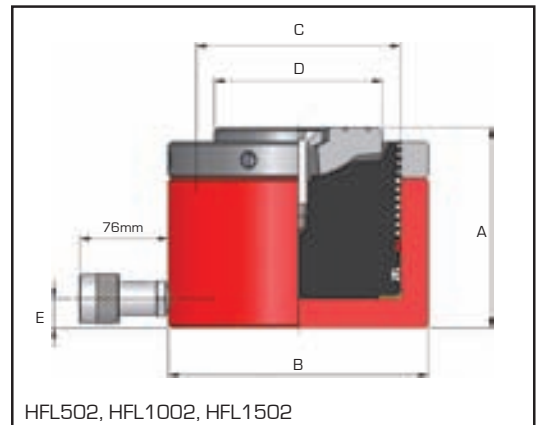

Model number	Capacity tonnes	Stroke mm	Oil cap. litres	Cyl. eff. area cm ²	Weight kg
HFL502	50	51	0.36	71.3	14.2
HFL1002	109	50	0.77	153.4	25.1
HFL1502	152	45	1.07	214.3	44.0
HFL2502	260	45	1.65	366.1	69.4
HFL5002	520	45	3.29	729.9	186.0

Dimensions in mm				
A	B	C	D	E
125	127	95	70	19
137	178	140	115	20
150	216	165	135	28
159	273	216	200	31
192	400	305	290	43